



The Coatinc Company®

We galvanize dreams – since 1885
www.coatinc.com

OUR PROCESSES

ALL INFORMATION AT A GLANCE



Germany • Netherlands • Belgium • Czech Republic • Slovakia • Turkey • Mexico
Est. 1885 Stiegener Aclengesellschaft  We galvanize dreams – for more than 130 years

CONTENTS

EVERYTHING REVOLVING AROUND SURFACES

OVERVIEW OF PROCESSES

Hot-dip galvanizing, high-temperature galvanizing, centrifugal galvanizing, passivation, powder coating, wet coating, anodization and duplex system	3
---	---

THE PROCESSES IN DETAIL

Hot-dip galvanizing.....	4
High-temperature galvanizing.....	5
High-temperature galvanizing, corrosion behavior	6
High-temperature galvanizing, accuracy of fit.....	7
High-temperature galvanizing, accuracy of fit, automotive.....	8
High-temperature galvanizing, weight reduction	9
High-temperature galvanizing, adjustability of layer thickness.....	10
Comparison of hot-dip galvanizing and high-temperature galvanizing	11
Centrifugal galvanizing	12
Passivation.....	13
Anodizing / anodic oxidation	15
Powder coating	16
Wet coating	17
Duplex, powder / wet (single-layer or multi-layer).....	18
Final finishing.....	19-20

PREREQUISITES

Corrosion protection planning.....	22
Steel composition.....	23
Manufacturing and constructing suitable for hot-dip galvanizing	24-25
Manufacturing and constructing suitable for anodizing.....	26-27

GENERAL

DAST directives	28
FAQ: DAST	29-30
FAQ: hot-dip galvanizing	31
FAQ: duplex.....	32



LIVING UP

TO A LONG TRADITION OF SURFACE FINISHING

Since 1885, we have stood for the perfect protection from corrosion, for maximum durability and lowest maintenance expenses for steel and other metals. Whether normal or high-temperature galvanizing, powder coating, wet coating as well as other coating technologies (anodizing and passivation), The Coatinc Company is among the most important providers of surface finishing in Europe – with their wholly-owned companies in Germany, the Netherlands and Belgium, other affiliated companies in Turkey, the Czech Republic and Slovakia, Mexico and California.

As a flexible and professional system provider, we anticipate future tasks of our customers and realize on a powerful basis individually developed solutions with motivated employees, smart processes and state-of-the-art technical equipment.



AT A GLANCE OUR PROCESSES



Hot-dip galvanizing

HOT-DIP GALVANIZING

When steel is dipped in molten zinc at 450 °C, a resistant alloy layer made of iron and zinc is formed on the contact surface and over it a very tightly adhering coat of pure zinc. Zinc acts as a sacrificial anode that protects the steel underneath from corrosion until the iron-zinc alloy layer is fully used up.



High-temperature galvanizing

HIGH-TEMPERATURE GALVANIZING

In high-temperature galvanizing, very thin, variable layer thicknesses of approx. 25 to 80 µm can be applied in a controlled way from up to 630 °C. High-temperature galvanized parts feature a definitely increased surface hardness, optimum capability of being coated and a high level of accuracy, which is especially ideal for components with a fine geometry – all that developed for the needs of the automotive industry.



Centrifugal galvanizing

CENTRIFUGAL GALVANIZING

Centrifugal galvanization means that small parts or bulk materials are dipped with the help of a circular container and centrifuged immediately after lifting them from the zinc bath. This rotation process removes excess zinc, and a homogeneous zinc coat emerges. Centrifugal galvanization provides excellent corrosion protection, mechanical resistance and good fitting accuracy.



Passivation

PASSIVATION

Passivation prevents or considerably slows down the chemical reaction of the zinc with substances in the environment. Thus passivation layers improve the corrosion behavior of the zinc coat.



Anodization

ANODIZING / ANODIC OXIDATION

In the anodizing process, aluminum parts are connected to a positive pole (anode) in a bath of diluted sulfuric acid. In the electrochemical process (DC 8,000 to 12,000 ampere), oxygen (O₂) bonds directly with the aluminum. The newly formed, highly corrosion-resistant aluminum oxide (Al₂O₃) can absorb pigments or other substances immediately after the anodization, so individual metallic colors can be created. Anodized material is no longer electrically conductive.



Wet coating

WET COATING

Wet coating is a coating method in which a steel component, or galvanized steel component, is coated with wet paint. The color groups, surface finish and gloss level are freely selectable. The exact specification of the coating can be designed according to technical requirements and customer wishes. Independent of this, individual coating systems can be realized in consultation with the paint manufacturers. This includes fire protection systems.



Powder coating

POWDER COATING PROCESS

Powder coating is a coating process in which an electrically conductive material is coated with powder paint. We use powder coatings based on polyester resin (SP) because, for one, they are particularly weather-resistant (good UV resistance); secondly, their color stability is considerably higher than that of epoxy resin (EP). With respect to multi-layered systems, we use epoxy resin as a base coat, though.



Duplex
Zn + powder

GALVANIZING PLUS POWDER COATING

The duplex method “Zn + powder” is a top-quality corrosion protection system consisting of zinc galvanizing in combination with one or several subsequent, colored powder coatings. Components coated with this method have a service life that is 1.2 to 2.5 times longer than the sum of respective duration of protection of galvanizing and coating. In multi-layered systems, we use epoxy resin as a base layer since it ensures a smoother surface in the final result.



Duplex
Zn + wet

GALVANIZING PLUS WET COATING

The duplex method “Zn + wet” is a supplementary corrosion protection system consisting of a galvanizing in combination with one or several subsequent, colored wet coatings. Components coated with this method have a service life that is 1.2 to 2.5 times longer than the sum of respective duration of protection of galvanizing and coating.

CORROSION PROTECTION SUSTAINABLE AND PROVEN



Hot-dip
galvanizing

Hot-dip galvanizing has been a tried-and-tested method for centuries. When steel is dipped in molten zinc at approx. 450 °C, a coat forms on the steel part as a result of the mutual diffusion of the liquid zinc and the steel surface. This coat consists of differently composed iron-zinc alloy layers and over it a very tightly adhering coat of pure zinc. The zinc layers are applied by diffusion according to DIN EN ISO 1461.

Even in the case of smaller damages to the coat of zinc, the zinc protects the steel on account of its electrochemical voltage potential (cathodic protection). Special advantages such as corrosion protection on the inside and outside surface of the component or optimum edge protection round off the advantages of this method.

WELL APPLIED

After the incoming goods inspection, the parts are charged with the help of devices according to their shape and type. During the subsequent wet chemical **pretreatment**, nearly all contaminations are removed and the steel surface is activated for the following galvanization process with a flux agent solution. A rapid steep dipping process, product-dependent short dipping time, cleaning of the bath surface prior to the slow steep drawing-out process and the removal of any excess zinc ensure a successful hot-dip galvanizing process.

SURFACE CONDITION

The formation of the iron-zinc alloy layers during the hot-dip galvanizing process can take place at very different speeds. The chemical composition of the steel in relation to silicon and phosphorus is of crucial importance here, because in certain concentration ranges, these elements accelerate the iron-zinc reaction with the result that gray and thick zinc coats emerge. In order to achieve visually perfect results, you should take these issues into account as early as in the planning phase.

WELL EQUIPPED

Hot-dip galvanizing is a highly effective corrosion protection with a very long duration of protection for steel components exposed to changing weather conditions. Zinc coatings are a low-maintenance or maintenance-free corrosion protection.

When looking at the costs incurring for corrosion protection measures, including maintenance and repair costs, during the useful life of steel constructions, hot-dip galvanizing is by far the most cost-effective measure to protect steel constructions and many other steel products from corrosion.

ADVANTAGES AT A GLANCE

- Resistant alloy layer
- Durability
- Cathodic self-healing effect
- Corrosion protection of inside and outside surfaces
- Edge protection

THE BENCHMARK FOR PRECISION PARTS



High-temperature
galvanizing

High-temperature galvanizing is an advanced method of hot-dip metal coating in which the steel parts are finished in a ceramically and inductively heated bath at temperatures of 560 °C to 630 °C. Depending on the customer's request, very thin zinc coatings from approx. 25 µm to 80 µm can be applied in accordance with DIN EN ISO 1461. The protective effect of a high-temperature galvanized zinc alloy layer is identical to that of hot-dip galvanizing. Special product requirements, e.g. excellent fitting accuracy, greater surface hardness and capability of being coated, are other advantages of this method.

ACCURATE

The higher galvanizing temperature and associated considerably lower viscosity of the liquid zinc alloy result in improved zinc run-off properties on the component. With prior component matching, even very small holes or threaded parts can be hot-dip galvanized without requiring reworking. This supports in particular the requirement of ready-to-install products.

EXTREMELY THIN, EXTREMELY HARD

With the iron-zinc alloy layer consciously produced in high-temperature galvanizing, a high level of surface hardness with improved abrasion and wear properties is achieved. Especially automotive components exposed to stone chipping are provided with an ideal protective armor. With special process control, extremely thin, weight-saving zinc layer thicknesses with a narrow fluctuation range can be generated on a reproducible basis.

COATABLE

Thanks to the controllable thickness of the zinc layer, high surface precision is guaranteed, largely independent of the material. Uncontrolled growing of the zinc layer thicknesses – especially on welds or in the edge area – is absolutely minimal. Elaborate final finishing work is reduced to a minimum. In addition, the fine micro-roughness of the zinc layer offers improved adhesion for all subsequent coating systems.



ADVANTAGES AT A GLANCE

- Accuracies are preserved
- Low weight increase
- High level of surface hardness
- Improved abrasion and wear properties
- Cathodic self-healing effect
- Very good price performance ratio

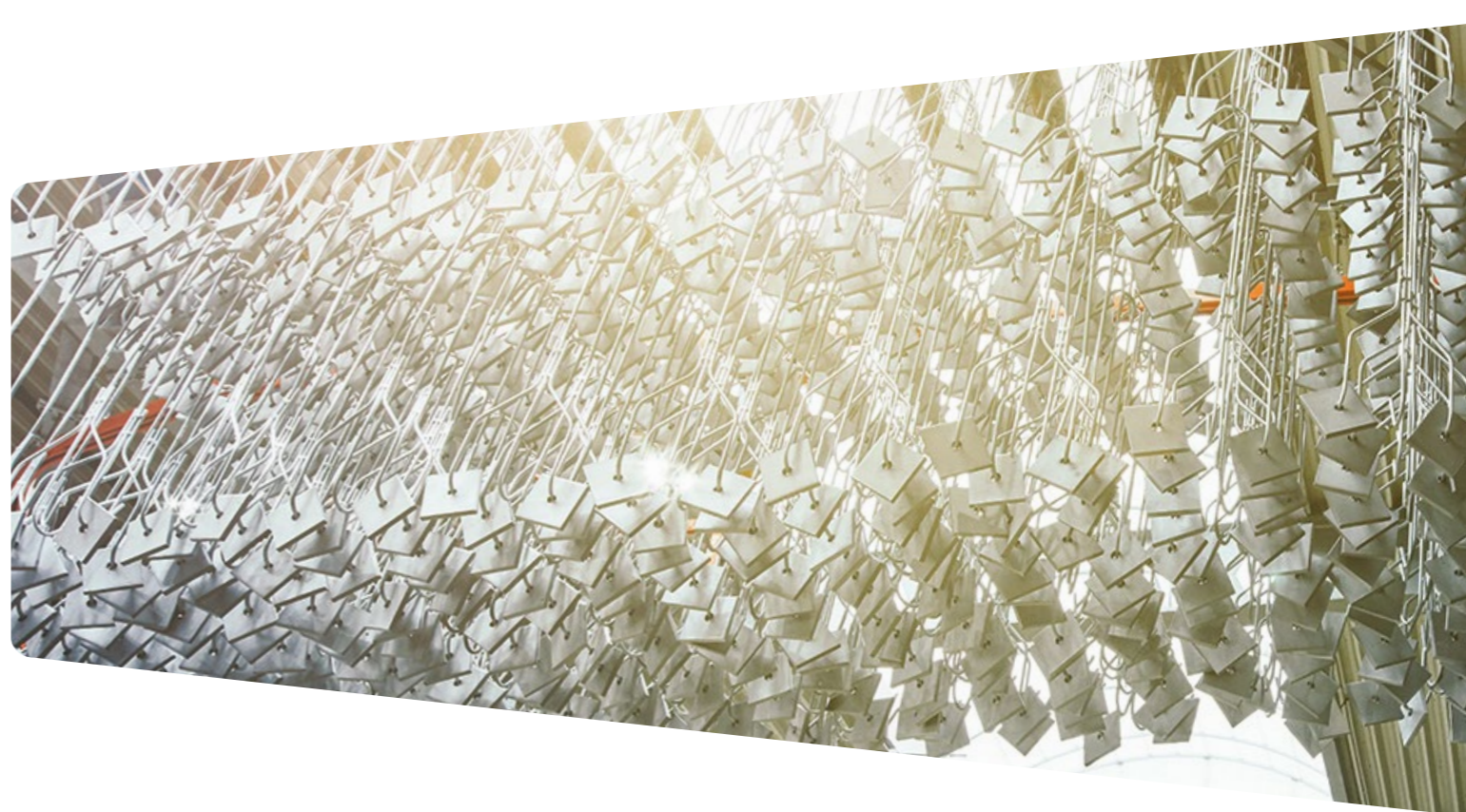

HIGH-TEMPERATURE GALVANIZING CORROSION BEHAVIOR

OPTIMUM CORROSION BEHAVIOR OF HTV IN THE SALT SPRAY TEST

The anti-corrosion achievement of high-temperature galvanizing is based (as with all DIN EN ISO types of hot-dip galvanizing) on the formation of protective topcoats that emerge due to weather effects on the surface of hot-dip galvanized steel parts over the course of a few weeks or months. These topcoats consist primarily of alkaline zinc carbonate, whose formation depends heavily on the availability of carbon dioxide.

The so-called salt spray test – by itself, it does not deliver any results relevant to actual practice because it does not justice to the corrosion behavior of the zinc layer – shows this special value for high-temperature galvanizing when stone chipping is added.

Tie rod, high-temperature galvanized
After a prior stone chipping test, corrosion development after 480 h in salt spray testing



Tie rod, D-KTL coated (thick cathodic dip painting, English abbreviation: EDP)
After a prior stone chipping test, corrosion development after 120 h in salt spray testing

IN A NUTSHELL

- High level of mechanical load capacity
- Top-notch stone chipping protection properties

HIGH-TEMPERATURE GALVANIZING ACCURACY OF FIT

EASY MOVE OF THREADS AS A RESULT OF IMPROVE ZINC RUN-OFF PROPERTIES

Thanks to the higher galvanizing temperature – compared to conventional hot dip galvanizing – and thanks to the significantly lower viscosity of the liquid zinc alloy in the zinc kettle, the result is improved zinc run-off properties on the part to be galvanized. These properties are further improved by special galvanizing equipment and the use of other aids. Fine threads, fits and surface geometries are precisely hot-dip galvanized.

Subsequent machining can often be avoided. With this, a component is created that has every right to call itself galvanized.

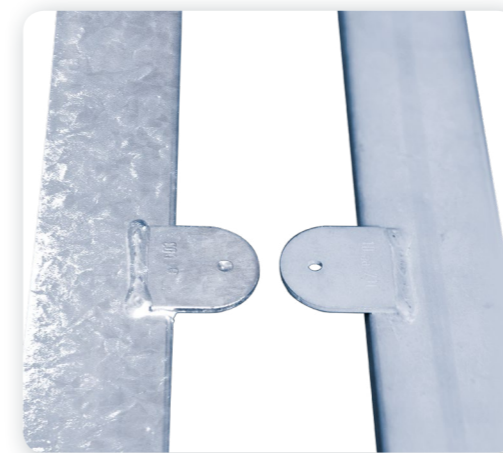

Hot-dip galvanizing with closed drilling hole

High-temperature galvanizing with $d = 4.0$ mm hole

IN A NUTSHELL

- Improved zinc run-off properties
- High level of process reliability
- Reduction of reworking
- Accuracy
- Smooth threads

The processes in detail
High-temperature galvanizing
(HTV), corrosion behavior

The processes in detail
High-temperature galvanizing,
accuracy



Underbody

The processes in detail
High-temperature galvanizing,
automotive

ACCURACY IN THE AUTOMOTIVE AREA

HIGHER TEMPERATURE OF THE ZINC BATH (560 ° - 630 °C) – LOW VISCOSITY OF THE LIQUID ZINC – IMPROVED ZINC RUN-OFF BEHAVIOR

The Coatinc Company is able to galvanize an automotive assembly part with mounting bracket reliably in series in such a way that, without the necessity of reworking, with a given hole of 4.2 mm a guaranteed diameter of 4.0 mm is not fallen short of.

Any type of manual reworking implies a possible quality risk, also in terms of corrosion protection. Therefore it is the declared goal to get components from the galvanizing process that are largely free of the necessity of reworking. We pay special attention that the area of the rim holes are completely free from any zinc thickenings. With this transverse control arm, the bushings were pressed in before it was installed in the vehicle.

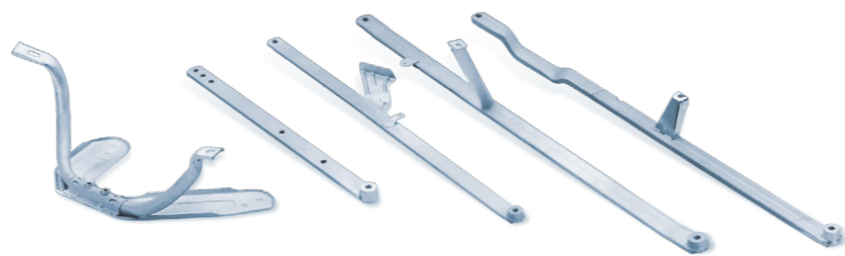

IN A NUTSHELL

- Improved zinc run-off properties
- High level of process reliability
- Reduction of reworking
- Accuracy
- Smooth threads

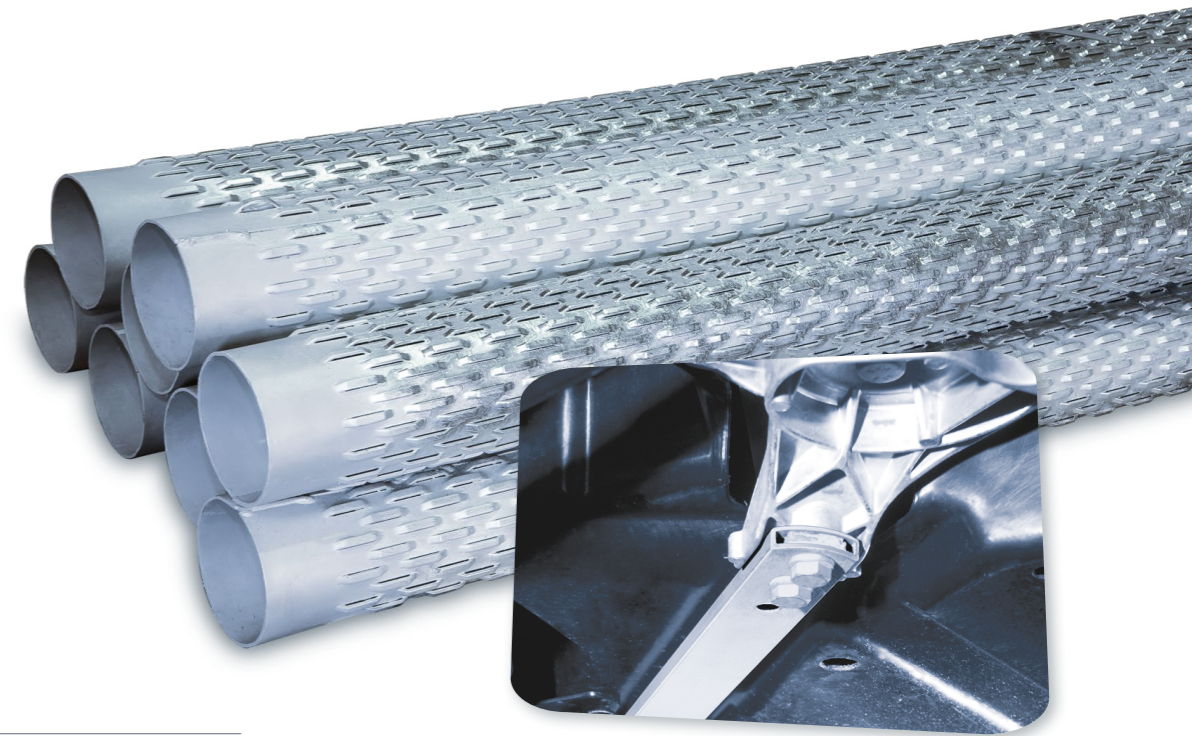

ZINC BIG FOR MORE SUCCESS

WEIGHT REDUCTION THROUGH TARGETED LAYER THICKNESS ADJUSTMENT
IN HIGH-TEMPERATURE GALVANIZING

By means of a process control in the temperature range of 560 ° - 630 °C, developed in-house by The Coatinc Company, the running diffusion processes are controlled in high-temperature galvanizing in such a way that very thin zinc thicknesses can be generated on a reproducible basis. What's special here is that customer-specific requirements can be precisely implemented.

The chemical composition of the steel, in particular the silicon content, frequently responsible for the uncontrolled growth of the layer thickness in hot-dip galvanizing, are completely eliminated here.

Zinc layer thickness as of 25 µm and upward are possible. This property and the high level of abrasion and wear resistance are in high demand in the automotive industry, in particular because the weight reduction enables fuel savings and a resource-conserving use of materials and thus sustainability.

In comparison with other metallic corrosion protection methods, high-temperature galvanizing closes a gap that has been open for a long time.

The processes in detail
High-temperature galvanizing,
weight reduction

IN A NUTSHELL

- Weight reduction
- No uncontrolled growth of layer thicknesses
- High wear resistance
- High abrasion resistance
- Sustainability

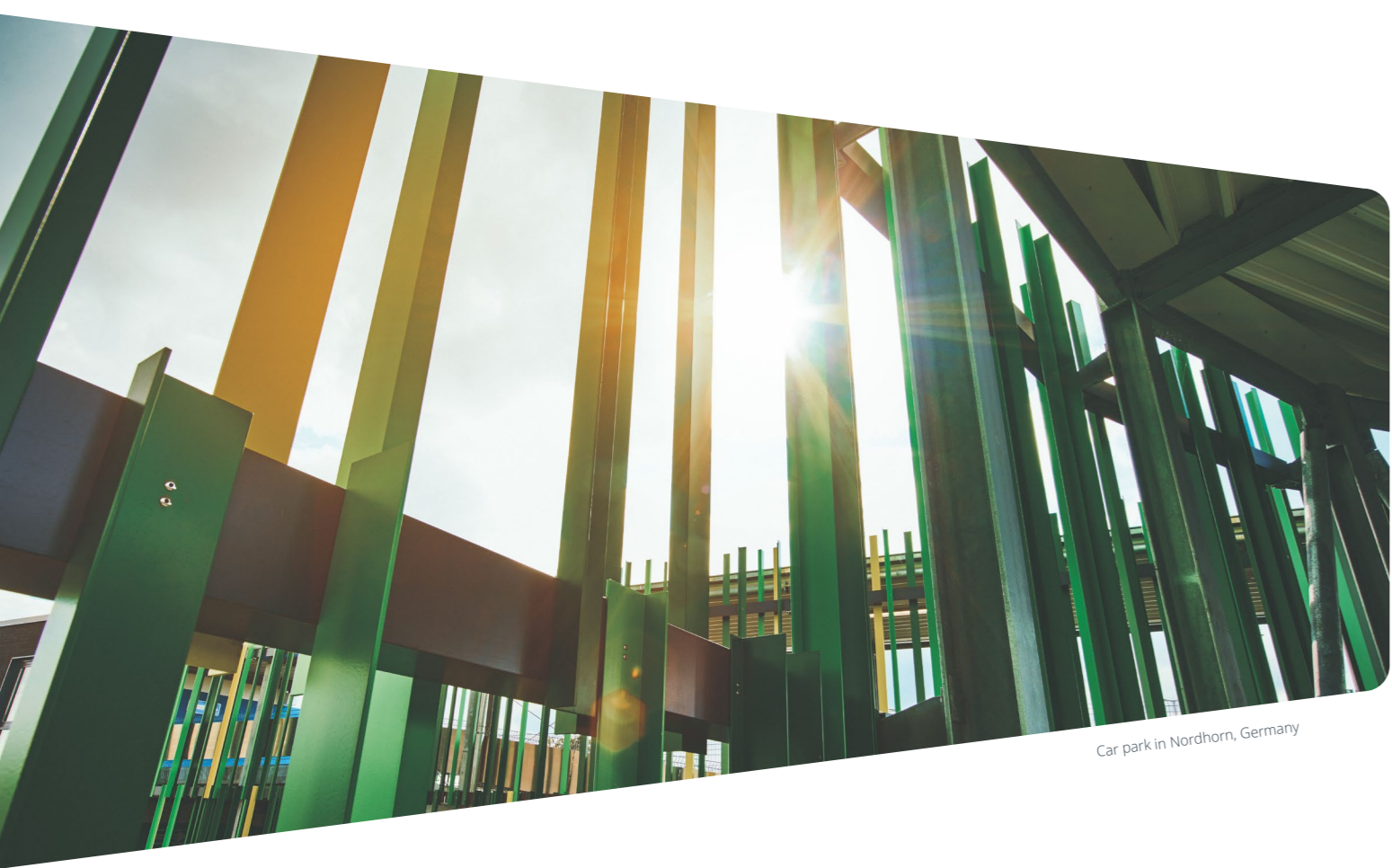

Car park in Nordhorn, Germany

VARIABLE LAYER THICKNESSES FROM 25 MICROMETERS TO 100 MICROMETERS

High-temperature galvanizing (HTV) is a form of hot-dip zinc coating that is suitable for fine geometries. At temperatures of 560 °C to 630 °C, assembly parts are dipped in a ceramic zinc kettle for 5 to 10 minutes. Thanks to the controllable thickness of the zinc layers, from 25 to 100 µm, ready-to-install parts can be galvanized on a reproducible basis. The phases responsible for uncontrolled growth of layer thicknesses in conventional hot-dip galvanizing (NTV) generally do not exist in HTV.

Phase	Compound	% Fe	Crystal structure	Density (kg/dm ³)	NTV	HTV
Eta	Zn	≤ 0.03	hexagonal	7.14	•	
Zeta	FeZn ₁₃	5-6	monoclinic	7.18	•	
Delta	FeZn ₇ / FeZn ₁₀	7-12	hexagonal	7.25	•	•
Gamma	FeZn ₇ / FeZn ₁₀ / FeZn ₂₁	21-28	cubic	7.36	•	•

- IN A NUTSHELL**
- Adjustable layer thickness
 - Weight reduction
 - High grade of hardness
 - Gap to electroplating is closed
 - Internal pipe galvanizing through dipping
 - Micro-roughness of the Zn-Fe layer
 - Unique galvanizing process

COMPARISON OF METHODS HOT-DIP GALVANIZING & HIGH-TEMPERATURE GALVANIZING

HOT-DIP GALVANIZING (NTV)	HIGH-TEMPERATURE GALVANIZING (HTV)
<p>HOLES AND SURFACES</p> <p>Depending on the steel grade, the galvanizing process creates wider ranges of zinc layer thicknesses. The outward surfaces and edges must be reworked. Holes of up to d = 8 mm must be redrilled. Tolerances must be coordinated individually in advance.</p>	<p>HOLES AND SURFACES</p> <p>Reworking surfaces and edges does not apply. In series production, reworking of holes from d = 4 mm and upward is not required.</p>
<p>STEELS</p> <p>The build-up of the zinc alloy largely depends on the Si and P alloy content of the steel.</p>	<p>STEELS</p> <p>The build-up of the zinc alloy is largely independent of the Si and P alloy content of the steel.</p>
<p>DISTORTION</p> <p>Look at an iron door with welded-on plates with a thickness of 2 mm, for example: a variance from the evenness may emerge. Due to the low galvanizing temperature of 450 °C, a distortion risk is not completely precluded but is minimized.</p>	<p>DISTORTION</p> <p>Due to the galvanizing temperature of up to 630 °C, the distortion risk is slightly increased.</p>
<p>BUSHINGS COVERS</p> <p>Previously, bushings had to be mechanically reworked after hot-dip galvanizing. Now there's the option of suitable cover caps that withstand the temperature load (approx. 450 °C) of hot-dip galvanizing.</p>	<p>BUSHINGS COVERS</p> <p>Owing to the thin zinc flow path, covering the bushings is not required. The hardness of the high-temperature galvanizing allows full functionality of the component.</p>
<p>ZINC AS A SACRIFICIAL ANODE</p> <p>Zinc is more of a base metal that protects the underlying steel from corrosion until the iron-zinc alloy layers are completely used up.</p>	<p>ZINC AS A SACRIFICIAL ANODE</p> <p>Zinc is more of a base metal that protects the underlying steel from corrosion until the iron-zinc alloy layers are completely used up.</p>
<p>CORROSION PROTECTION</p> <p>The protective effect of an HTV zinc alloy layer is identical to that of NTV. The thickness of the layer determines the length of the corrosion protection. The molten bath composition is determined for both methods in accordance with DIN EN ISO 1461; it also corresponds to the regulations of DIBt and has a pure zinc content of at least 98.5 %.</p> <p>Reworking is done carefully since the zinc layer can be damaged when handled improperly. This results in an impairment of the corrosion protection in the damaged spot.</p>	<p>CORROSION PROTECTION</p> <p>The protective effect of an HTV zinc alloy layer is identical to that of NTV. The thickness of the layer determines the length of the corrosion protection. The molten bath composition is determined for both methods in accordance with DIN EN ISO 1461; it also corresponds to the regulations of DIBt and has a pure zinc content of at least 98.5 %.</p> <p>Usually, HTV does not require reworking. In downstream operations, e.g. the pressing in of rubber buffers, damage is almost completely precluded due to the high grade of hardness of the HTV coat.</p>
<p>WELDS</p> <p>Due to the higher proportion of Si + P in the filler materials, growth occurs on the weld seams. Where evenness is important – e.g. in pipes – welds should be avoided all together, and seamlessly drawn pipes should be used instead of welded pipes.</p>	<p>WELDS</p> <p>No uncontrolled growing of the zinc layer thicknesses on the weld seams.</p>
<p>APPEARANCE</p> <p>Depending on the proportions of silicon and phosphorus, silvery to gray surfaces emerge in hot-dip galvanizing. Usually, silvery surfaces predominate.</p>	<p>APPEARANCE</p> <p>Industrial gray surfaces usually emerge after galvanizing. The iron-zinc alloy layer is completely grown, and there is no pure zinc layer.</p>
<p>DIMENSIONS/WEIGHTS</p> <p>Galvanizing of components with a length of up to 19.2 m with single dipping Galvanizing of components with a length of up to 30.0 m with double dipping Galvanizing of components with a height/width of up to 5 m with double dipping Max. unit weight: 18 t Combinations of maximum dimensions on request.</p>	<p>DIMENSIONS/WEIGHTS</p> <p>Galvanizing of components with a length of up to 4 m Max. unit weight: 800 kg Combinations of maximum dimensions on request.</p>

The processes in detail
Comparison of HTV / NTV



ANODIZING/ANODIC OXIDATION

FINISHING OF ALUMINUM



Anodization

ANODIZING/ANODIC OXIDATION, GENERAL

Anodizing is an accelerated electrochemical oxidation process in which the natural oxide skin of the aluminum is strengthened. In so doing, the transparent oxide layer becomes a lot thicker than the natural oxide layer. Essential advantages of this method are great corrosion resistance and long-term protection. Thanks to the transparent layer, the metal character is preserved.

HOW DOES ANODIZING WORK?

Aluminum parts are connected to a positive pole (anode) in a bath of diluted sulfuric acid. The electrochemical process (DC 0.5 ampere/dm² up to 2 ampere/dm²) produces oxygen (O₂), which bonds directly with the aluminum and generates aluminum oxide (Al₂O₃). The newly formed aluminum oxide can absorb pigments or other substances immediately after the anodization, so individual metallic colors are created. Due to the sealing, in which the pores of the layer are compacted, the surface is transformed into a sealed layer. This layer is not only very corrosion-resistant; it also remains clean and retains its color. Anodized aluminum is easy to recycle because the aluminum is protected by a metallic coating.

CORROSION PROTECTION WITH A WIDE RANGE OF PROPERTIES

There are various anodizing methods: anodic oxidation, hard anodizing, Nituff®, CompCote® or chromatic anodizing. With these methods, anodized layers come into being that have different properties – for example, specific layer thicknesses; specific colors or grades of hardness; a specific wear resistance; or strong anti-corrosion and sliding properties.

TECHNICAL FEATURES:

- The aluminum is free from black streaks after the process
- Resistant to most chemicals and solvents
- Layer thickness of up to 100 µm
- Hardness of up to 600 micro Vickers
- Higher wear resistance than hardened steel
- Breakdown voltage at approx. 40 volt/micro meter
- The layer thicknesses can be generated with great accuracy
- Anodized material is no longer electrically conductive

IN A NUTSHELL

- Strong corrosion and wear resistance
- Long-term protection
- Transparent coat
- Individual, metallic colors
- Easy to recycle
- High wear resistance



CENTRIFUGAL GALVANIZING SPECIALLY FOR SMALL PARTS



Automated or semi-automated centrifugal galvanizing has been specially developed for small parts that often do not have any or hardly any suspension points. For screws, nuts, nails, pins and similar bulk material, "excess" zinc is centrifuged from the parts in the rotation process. This improves both fitting accuracy and the evenness of the zinc coat on the surface of the component. In order to reduce the contact points, etc., of the galvanized parts, the small parts are usually cooled in a water bath.

COAT THICKNESSES OF "SMALL PARTS"

Although the terms "small parts" and "centrifugal goods" are used interchangeably in actual practice, the DIN EN ISO 1461 standard differentiates centrifuged and non-centrifuged parts by different coat thicknesses. For example: For centrifuged parts with a wall thickness of over 6 mm, the standard demands an average coat thickness of at least 50 µm to 85 µm in comparison to non-centrifuged parts.

APPEARANCE AND SURFACE QUALITY

By centrifugation, the so-called pure zinc layer is almost completely removed. As a result, centrifuged small parts usually have thinner zinc coats than similar components that were not centrifuged. For this reason, the zinc coat on the surface of the small parts usually has a light gray to medium gray appearance, not the typical silvery gloss as you would expect from usual batch galvanizing. It has to be added, though, that this is a purely visual effect that has no impact on the quality of the corrosion protection.

TYPICAL PRODUCTS

Centrifugal galvanizing is especially well suited for nails, pins or hooks – any form of wire pins. The treatment is also used for small parts made of section steel, steel bars and sheet metal. Small parts in this category encompass many forms and dimensions – for example, clamps, hinges or rope clamps. Screws, nuts and washers are also typical products for centrifugal galvanization.

IN A NUTSHELL

- Great accuracy
- Improved evenness of the zinc coat on the surface of the part
- Average coat thickness of at least 50 µm
- High surface quality



PASSIVATION

GLOSS PRESERVATION OF HOT-DIP GALVANIZING

Passivation prevents or considerably slows down the chemical reaction of the zinc with substances in the environment. Thus passivation layers improve the corrosion behavior of the zinc coat.

In actual practice, white rust can only become a problem with freshly galvanized parts because the protective top coats have not yet formed. Since the effect of moisture is an essential prerequisite, seasonal influences play a role. Time periods in which white rust occurs to a greater extent are fall and winter, because frequent rainfall, fog and low temperatures under the dew point facilitate the formation of white rust. Stacking freshly hot-dip galvanized parts in the wet grass, in an unfavorable position or flat on top one another, can result in white rust if there is also an intense exposure to moisture. Although the intention might be good, covering galvanized steel parts stored outdoors with tarps or plastic sheets usually does more harm than good. The moist air accumulates under the cover, condensate forms in the moisture-saturated air – an ideal climate for white rust.

Packaging also only makes sense as long as it is undamaged and no moisture penetrates the packaging. Problems with white rust arise particularly easily with hot-dipped galvanized bulk goods, e.g. screws or nails stored outside in moist wooden boxes or open containers. The formation of white rust is not connected to the galvanizing method and is no criterion for the quality of the galvanizing. Rather, we are dealing with a phenomenon here that depends greatly on weather conditions during the storage and transport of fresh hot-dip galvanized parts. The basic prerequisite for conserving the gloss is the right choice of steel.

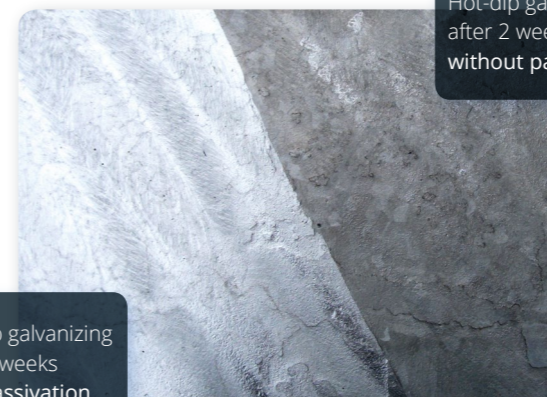

Hot-dip galvanizing after 2 weeks without passivation

Hot-dip galvanizing after 2 weeks with passivation

PASSIVATION OFFERS LONG-TERM PROTECTION FROM WHITE RUST:

- Effective protection from white rust, especially for outdoors
- Excellent temporary weather protection
- Free from chromium and organic solvents



POWDER COATING

COLORED CORROSION PROTECTION



We offer our customers powder coating with everything from a single source. The use of powder coating using polyester resin (SP) is standard for external applications. They are particularly resistant to weathering (good UV resistance). The chalking and discoloration behavior is significantly lower than that of epoxy resin powder (EP), which is primarily used for priming due to their high chemical and diffusion resistance.

THE FOLLOWING LAYER BUILD-UPS ARE POSSIBLE ON THE HOT-DIP GALVANIZED SURFACE:

Layer build-up on the basis of polyester resin (SP) or epoxy resin (EP)

- Powder-priming as an option for a better surface finish (appearance)
- Powder epoxy primer as an option for chemical stability (corrosion protection)
- Powder-SP topcoat is our standard for hot-dip galvanized surfaces
- Clear-coat powder coating to add gloss to matt pearl effect colors, for example
- Anti-graffiti powder coating on request, for being easier to clean

Color groups

- Single coats according to RAL or special colors on request
- Metallic coatings according to RAL or DB color or on request
- Iron mica coatings according to RAL, DB color or on request
- Pearl mica coatings RAL with major color deviations
- (single layer only in matt, gloss is possible by adding another clear coating)

Surface finish (unless otherwise specified at the factory)

- Smooth is our standard in all RAL and DB colors
- Coarse texture only on special request
- Fine texture possible for all DB colors (RAL 9006, RAL 9007 and other colors on request)

Gloss level (unless otherwise specified at the factory)

- Gloss is standard for white (RAL 9010 and 9016)
- Satin gloss for all RAL colors
- Matt/satin for DB and pearl mica hues, RAL 9005 are by default in satin gloss.



WET COATING

OPTIONAL SURFACE FINISH

It should be noted that the color group, surface finish and the degree of gloss can be chosen for wet coating and for powder coating alike. The exact specification of the coating can be designed according to technical requirements and customer wishes.

In the actual practice of wet coating, the rules and regulations of ZTV-ING / TL/TP-KOR, steel constructions, as well as the requirements of the Federal Highway Research Institute (BASt) are frequently applied. Independent of this, coating systems can be realized in consultation with the paint manufacturers.

ESSENTIALLY, THE FOLLOWING POINTS MUST BE OBSERVED:

- Surface prior to coating
- Selection of the coating material for primer and further coatings
- Number and thickness of the respective layers (corrosion protection class)

BY WAY OF EXAMPLE, WE PRESENT THREE POSSIBLE VARIANTS HERE:

I. a) Build-up in accordance with TL/TP-KOR

- Abrasive blasting in accordance with DIN EN ISO 12944-4
- Primer (2K-EP) and top coat (2K-PUR)
- 80 µm each

I. b) Build-up in accordance with TL/TP-KOR with hydro-primer

- Clean surface & processing within 24 hours of the galvanizing
- Primer (1K-Hydro) and top coat (2K-PUR)
- 80 µm each

II. Fire protection systems

- F30-F60 – factory coating
- F60-F90 – coating at construction site

III. Additional services

- On request, we offer:
- Coating at the construction site
 - Maintenance
 - Rehabilitation work

DUPLEX COATING ZINC AND COLOR

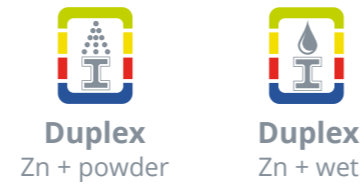

HOT-DIP GALVANIZING PLUS WET/POWDER COATING

In recent years, hot-dip galvanized parts have more and more frequently received an additional coat with the help of organic substances in order to achieve specially stressed components or in order to combine optimum corrosion protection with individual color designs. Basically, a distinction is made between powder coating and wet paint coating systems, which are applied following the hot-dip galvanizing. In most application cases, the component surface is first finished, swept or pretreated in the wet chemical process.

SIGNIFICANTLY INCREASED DURATION OF PROTECTION

If you look at the protection duration of the duplex system in comparison to the individual protection duration of the two separate systems, you will find the combination of both achieved a considerably higher protection duration – depending on the time at which the coating was carried out. This synergy effect brings about an extension factor of up to 2.5. The mechanisms of action of duplex systems is based on the mutual protection of both partners. For one, the zinc coat is protected by the coating from weather and chemical influences; hence abrasion is avoided. Secondly, the hot-dip galvanizing blocks or delays disponding, or the detachment of the coating in the case of damage. The zinc protects the steel, and the paint coat protects the zinc layer. Disponding and paint adhesion are dependent on the **pretreatment** prior to coating.

The multi-layer system – wet coating or powder coating

Double or multi-layer systems are recommended for use on the coast or outdoors; in industrial areas; in chemically stressed environments; for the use of de-icing salt in tunnels and on bridges; and for products for which you want to achieve a long service life.

How do multi-layer systems work in detail?

1. First, final finishing is carried out. Then the surface is blasted or pretreated with a wet chemical method (powder coating). In the case of wet coating, the type of surface preparation is agreed upon with the customer; or else it is prescribed by the system.

2. Depending on the chosen layer system, the application of epoxy resin on the substrate creates pore density, compensates for unevennesses and gets into corners and holes. Last but not least, the epoxy resin is a waterproof layer that is resistant to chemical attacks.

3. Finally, a polyester or polyurethane layer is applied. This layer not only ensures an attractive glossiness of the color but also for a smooth surface finish.

YOUR BENEFITS

- Functional and decorative
- Great appearance – even after a long time of use
- Significantly increased duration of protection through synergy effect

FINAL FINISHING IN HOT-DIP GALVANIZING

The coating of hot-dip galvanized parts with organic coating materials has definitely become a trend in recent years. Various motivational factors play a role here. They include:

- A desire for a special color design
- The requirement for boosting corrosion protection by means of an additional layer
- As a separating layer to prevent contact corrosion with different material combinations

Since the preparatory measures involve grinding and polishing, they are grouped together under the term of final finishing. The work on the surface to prepare the coating is subdivided into two parts:

INDUSTRIAL DIN FINISHING

Finishing with the lowest standard is finishing according to industrial standard. Here the component is processed according to the standard DIN EN ISO 1461. This means: All tips and drips are removed or rounded off to an extent that they cannot cause injury. Remaining zinc ash must be removed. Any flaws in the galvanizing are not improved with zinc dust paint as the coating system in the zinc dust paint may not homogenize with that of the later coating. The surface is not polished in this standard; it remains in its original state. Only any larger traces of hard zinc need to be removed. Roller traces and frays are not removed. The welding seam which normally extrudes in conventional galvanizing due to the materials are not filed. The manufacturer of the components should note the following when preparing:

- The edges of the components should be at least broken off and filed in the case of laser edges to exclude later adherence problems.
- The component surface should have a unified degree of finish (roughness, degree of rust, scarredness ...) as this greatly defines the later appearance of the surface of the hot-galvanizing and therefore also the coating.
- Steels from the ranges 1 and 3 (sebisty steels) should be selected as materials for a subsequent coating, as only these ranges can achieve relative smoothness and thin coats of the surface refiner.

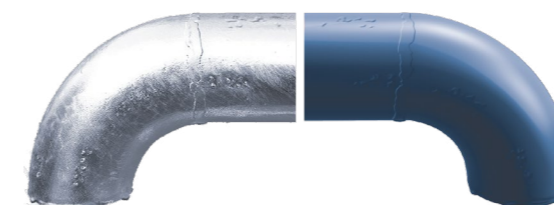

Industrial DIN finishing

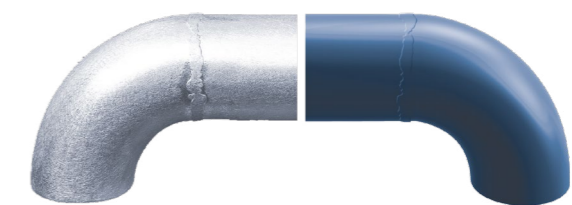

Decorative finishing



The processes in detail
Final finishing

DECORATIVE FINISHING

AESTHETICS & CORROSION PROTECTION

The finish suitable for decorative requirements is the one that is most often chosen. It provides a mixture of both aesthetics and corrosion protection. A finish of this standard fundamentally meets all industrial standards for finishes. While the industrial standard only removes and rounds off the side effects directly caused by hot dip galvanizing, such as paint drips or zinc nibs, the surface in total here is processed much more than just required by the standard. The decorative finish clears the surface of roughness, in particular traces of hard zinc and drips. This improved surface smoothness can only be carried out on areas that can be easily reached by machines. If the materials generally require an increased coating thickness, the possibility of polishing and achieving a "smooth" surface is limited. In this case, separate agreements should be made between the client and supplier, and finishing can only be carried out at cost. Work carried out for decorative finishing may only effect the surface in such a way that the valid DIN EN ISO 1461 is still fulfilled. As finishing involves mechanical **treatment**, the minimum thickness of zinc coating required by DIN EN 1461 cannot be guaranteed.

THE FOLLOWING REQUIREMENTS MUST BE FULFILLED TO PROVIDE A FINISH ACCORDING TO THE DISPLAYED STANDARD:

- All edges must be broken and filed.
- The components may not contain reactive steels (see worksheets on hot-dip galvanizing).
- Ways of hanging the items should already be planned in construction – at points that can either be well polished or that cannot be seen.
- The components should be free of rolling defects and other surface errors. If these should occur more frequently than normal (1 fault per square decimeter), special agreements must be made.

THE FOLLOWING MUST BE ADHERED TO FOR DECORATIVE FINISHING:

- Complete polishing of the surfaces and removal of all nibs and drips where possible by machine or in the construction
- Leveling out of points without zinc coating
- Smoothing of zinc nibs and hanging points
- Removal and leveling of material faults.

The extruding welding seam is not removed.

COMPLETION

The rules listed here apply to both hot-dip galvanizing and high-temperature galvanizing. There is no question that the advantages of high-temperature galvanizing for the surface condition result in heightened quality and that non-extruding welds are already included in decorative or industrial standardization. However, not all constructions allow for high-temperature galvanizing. Reasons for this can be distortion risks related to construction and temperature as well as limited kettle dimensions. Unless agreed upon otherwise, the standards and regulations in steelwork apply to the distortion of components. In the event that internal tensions result in distortions outside the standards, The Coatinc Company is obligated to notify and block the customer material prior to the handover to the coating company; not to carry out any rectification work, however, unless it was included in the offer.



„Waldsofa“, Schmallingenberg, Germany.

The processes in detail
Final finishing

PLANNING OF CORROSION PROTECTION

LONG-TERM SAFEGUARDING

The corrosion of steel depends on various factors, e.g. moisture, chemical influences, surface contamination, etc.

Tables 1 and 2 list the corrosion exposures and abrasion rates of corrosiveness categories C1 to CX in brief form. You'll find a more detailed description in DIN EN ISO 14713-1. By dividing the zinc layer thickness of your component by the speed of corrosion prevailing at the location of use, you get the minimum period of protection. For example: With a zinc coat of 85 µm and an environment in corrosiveness category C3, you have a protection period of at least 40 years and at the most > 100 years.

The protection period can be considerably extended by the additional application of organic coatings (see page 18-19 and 20). In addition to the selection of the right material (see page 26), the rules for construction suitable for hot-dip galvanizing (see page 28-30 and 34-38) must be observed so your construction can be effectively protected from destruction caused by corrosion for many decades.



Prerequisites
Planning of corrosion protection

Prerequisites
Steel composition

Table 1 – CORROSION EXPOSURE

Corrosiveness category	Typical inside environment	Typical outside environment	Corrosion exposure
C1	Heated rooms with low relative humidity and minor air pollution.	Dry and cold climatic region, atmospheric environment with very low air pollution and little wetness.	very low
C2	Unheated rooms with fluctuating temperature and humidity. Rare condensation and low air pollution.	Temperate climatic region, atmospheric environments with low air pollution. Dry or cold climatic region, atmospheric environment with short-time wetness.	low
C3	Rooms with occasional condensation and moderate production-related air pollution.	Temperate climatic region, atmospheric environment and medium pollution or slight chloride pollution.	medium
C4	Rooms with frequent condensation and high production-related air pollution.	Temperate climatic region, atmospheric environment and high pollution or considerable chloride pollution.	high
C5	Rooms with very high condensation and/or high production-related air pollution.	Temperate and subtropical climatic regions, atmospheric environment with very high pollution and/or substantial chloride pollution.	very high
CX	Rooms with almost constant condensation or long exposure periods with a strong impact or moisture and/or high level of production-related air pollution.	Subtropical and tropical climatic regions (very long periods of exposure to wetness), atmospheric environment with very high pollution, including accompanying production-related pollution and/or heavy chloride pollution.	extreme

Table 2 – ABRASION RATE

Corrosiveness category	Thickness reduction per year in µm	
	Unalloyed steel	zinc coat
C1 - very low	≤ 1.3	≤ 0.1
C2 - low	> 1.3 - 25	> 0.1 - ≤ 0.7
C3 - medium	> 25 - 50	> 0.7 - ≤ 2.0
C4 - high	> 50 - 80	> 2.0 - ≤ 4.0
C5 - very high	> 80 - 200	> 4.0 - ≤ 8.0
CX - extreme	> 80 - 200	> 8.0 - ≤ 25

THE COMPOSITION OF THE STEEL

ITS INFLUENCE ON THE GALVANIZING RESULT

In hot-dip galvanizing, there is virtually no way to influence the growth of the iron-zinc alloy layers, which depends on the composition of the steel. In order to avoid any difficulties in hot-dip galvanizing, the customer should, whenever possible, use steels whose composition is outside of the unfavorable scope (see chart). When ordering steel, it is important to ensure that the steels are suitable for hot-dip galvanizing. With steels containing Si in particular, a fierce iron-zinc reaction can take place, causing the proportion of Fe-Zn alloy layers in the zinc coat to be larger than normal. The zinc layer is then thicker than required, increasing the corrosion protection value. On the other hand, a thicker zinc layer entails lower adhesion strength of the zinc coat on the steel. Up to now, this phenomenon was observed in particular with silicon contents of around 0.03 % to 0.13 % and over 0.28 %. With Si contents below the so-called Sandelin effect, the phosphorus content also plays an important role. Up to

- 0.035 % of silicon are harmless if the phosphorus content is < 0.01 %,
- 0.06 % silicon with 0.01 % phosphorus already result in extreme layer growth,
- 0.02 % silicon or less are harmless with a phosphorus content of < 0.02 %.

SUITABILITY OF THE STEEL

Steel grade	Capability of being galvanized – HTV	Special feature
Unalloyed structural steels (e.g. S235, S355, E295)	Very good to good, depending on the surface of the basic material	Almost no influence of the steel-alloy elements of Si and P on the alloy formation
Fine-grained structural steels (e.g. S275, S420, S460)	Good – changes in mechanical characteristics – emergence of a pronounced yield point possible (Re > Rp 0.2); reduction of elongation to rupture as of approx. S420	From approx. Rm = 1.000 N/mm ² , measures for the prevention of hydrogen embrittlement must be implemented
High-strength and ultra-high-strength steels	Poor or not at all – a strong decline in tensile strength with ultra-high-strength steels (oil hardening steel stronger than air hardening steel)	From approx. Rm = 1.000 N/mm ² , measures for the prevention of hydrogen embrittlement must be implemented
Cast steel (e.g. GS-38, GS-60)	Good	Components must be sandblasted, and the surface areas must be free from shrink holes and molding sand
Gray cast iron (e.g. GG-10, GG-20)	Quite varying but mostly poor – test zinc coatings with the respective cast quality are necessary.	Components must be sandblasted, and the surface areas must be free from shrink holes and molding sand

THICKNESS OF THE ZINC COAT ACCORDING TO DIN EN ISO 1461

Minimum layer thicknesses in batch galvanizing – excerpt from DIN EN ISO 1461

Parts and their thickness [mm]	Local layer thickness (minimum value) [µm]	Ø layer thickness (minimum value) [µm]
Steel ≥ 6 mm	70	85
Steel ≥ 3 mm to < 6 mm	55	70
Steel ≥ 1.5 mm to < 3 mm	45	55
Steel < 1.5 mm	35	45
Cast ≥ 6 mm	70	80
Cast < 6 mm	60	70



Passendes Bild einfügen

MANUFACTURING AND CONSTRUCTING SUITABLE FOR HOT-DIP GALVANIZING

NOTES

- DIN EN ISO 1461: "Hot-dip galvanized coatings on fabricated iron and steel articles" must be observed.
- NEW! According to Building Rules List A, the DASt directive 022: "Hot-dip galvanizing of load-bearing steel components" must be observed for load-bearing components.
- Hot-dip galvanized constructions include hot-dip galvanized fasteners in accordance with DIN EN ISO 10684.
- Components must be supplied free from paint (coatings), welding slag or welding residues (e.g. welding sprays, residue from the gas-shielded welding), etc., since these substances cannot be removed in the pretreatment and result in flaws.
- Steels with critical silicon contents have a tendency to form thick zinc coats with a gray appearance.
- To avoid reworking, bolt holes should be larger than 8 mm, if possible, and 2 mm above the nominal diameter.
- Transport and assembly damage to the corrosion protection must be professionally repaired.
- Gaps and pores, e.g. in the welded joints, due to construction and/or manufacturing must be avoided.
- Adhere to a suitable weld sequence.
- Chose symmetrical cross-sections, if possible.
- Create expansion possibilities (pay heed to the change in the component length 5 mm per meter at 450 °C).
- Avoid different material thicknesses as much as possible ($t_{max} / t_{min} \leq 5$).
- Inlet and outlet possibilities must be provided for frame constructions from open profiles as well.
- Overlapping surfaces must be avoided, if possible.

CHECK LIST, PRODUCTION

- No paint / sprays / weld slag
- No decals / markings
- Openings in the base plate area
- Position ventilation and suspension points

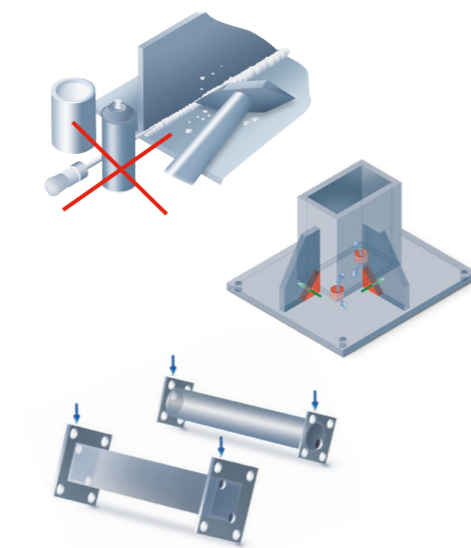

CHECK LIST, CONSTRUCTION

- Weld in the sleeves in a flush manner
- Introduce beading / tilting
- Visible holes/hidden holes controllable
- Do not weld extensively
- Openings in complex constructions

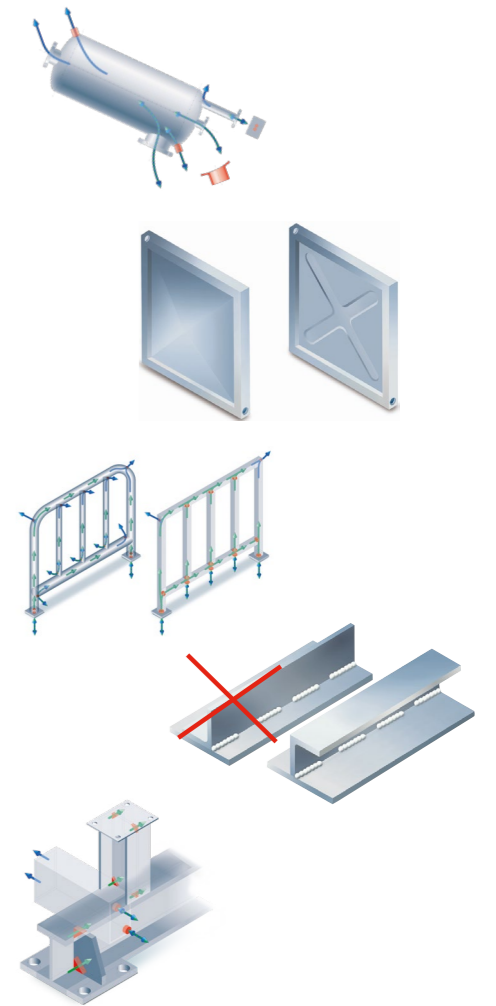

The minimum sizes in the table below apply to medium-sized constructions up to a length of approx. 6 m. With long profiles, the size and number of holes must be increased. Due to risk of explosion, hot-dip galvanizing of hollow constructions without openings is not possible. The arrangement and size of the holes affect the quality of hot-dip galvanizing.

Hollow profile dimensions in mm, smaller than			Minimum hole \varnothing in mm with a respective number of openings of		
			1	2	4
15	15	20 x 10	10		
20	20	30 x 15	10		
30	30	40 x 20	12	10	
40	40	50 x 30	14	12	
50	50	60 x 40	16	12	10
60	60	80 x 40	20	12	10
80	80	100 x 60	20	16	12
100	100	120 x 80	25	20	12
120	120	160 x 80	30	25	20
160	160	200 x 120	40	25	20
200	200	260 x 140	50	30	25

LEGEND FOR THE TABLE:

A hollow profile with the dimensions of 60 mm x 40 mm at each end require either:

- at least a single opening with a diameter of 16 mm or
- at least two openings with a diameter of 12 mm or
- at least four openings with a diameter of 10 mm.

Note:

Openings 25 % of the diameter are preferable in accordance with DIN EN ISO 14713.

MANUFACTURING AND CONSTRUCTING SUITABLE FOR ANODIZING

GENERAL MATERIAL RECOMMENDATIONS FOR NITUFF® & HARD ANODIZING

Alloy series	Mostly used	Processability	Nituff® & hard anodizing
1100	1100	Alloy is too soft for most applications	Excellent corrosion protection & hardness Dark bronze/gray at 50 µm
2000	2024 2014 2011	Excellent processability Avoid sharp corners	Weak to good corrosion protection & hardness Bronze/gray at 50 µm
3000	3003 3103	Good processability	Good corrosion protection & hardness 50 µm maximum thickness Good for black colorations Gray/black at 50 µm
5000	5052	Good weldability & moldability	Good corrosion protection & hardness Bronze/black at 50 µm
6000	6061 6063	Excellent dimensional stability Good weldability Good displacement	Excellent corrosion protection & hardness Perfect for reaming/wrapping/smoothing With a thickness of 50 µm: 6061-T6 almost black 6061-T651 bronze/black 6063 dark bronze
7000	7075	Good processability Susceptible to corrosion	Adequate corrosion protection & hardness Gray/bronze at 50 µm

Finishing with Nituff® and hard anodizing can only be done on aluminum. Basically, most alloys can be processed – however, alloys with a low content of copper and silicon deliver the best results. The table shows the details of the aluminum alloys processed that are very often used for these coatings. The selection of the material is of crucial importance for the quality of the coating. The exact selection of the aluminum alloy and temperature is equally important.

GENERALLY USED ALUMINUM ALLOYS

Alloy	Description	AMS specification	Federal specifications
1100-F 1100-H14 1100-H14	Rods, rod material, hot-rolled or cold finished Sheets, plates Seamlessly drawn pipe material	AMS-4102 AMS-4003 AMS-4062	FED-QQ-A-225/1 FED-QQ-A-250/1 FED-WW-T-700/1
2024-T3 2024-T3 2024-T4 2024-T6	Rods, rod material, wire, profile and pipe material Sheets, plates Rods, rolled or cold finished Rods, rod material, wire, drawn	AMS-4152 AMS-4037 AMS-4120 AMS-4120	FED-QQ-A-200/3 FED-QQ-A-25/4 FED-QQ-A-225/6 FED-QQ-A-225/6
3003-H14 3003-H14	Sheets, plates Seamlessly drawn pipe material	AMS-4008 AMS-4067	FED-QQ-A-250/2 FED-WW-T-700/2
5052-F 5052-H32 5052-H34	Rods, rolled or cold finished Sheets, plates Sheets, plates	AMS-4114 AMS-4016 AMS-4017	FED-QQ-A-250/8 FED-QQ-A-250/8
6061-T6 6061-T6 6061-T6 6061-T6 6061-T6 6061-T651 6061-T6511 6063-T6	Extruded rod, profile and pipe material Rods, resistance-welded rings Hollow profiles, molded parts Seamlessly drawn pipe material Sheets, plates Sheets, plates Extruded rod material, wire material, profile and pipe material Extruded rod material, wire material, profile and pipe material	AMS-4150 AMS-4117 AMS-4113 AMS-4083 AMS-4027 AMS-4027 AMS-4173 AMS-4156	FED-QQ-A-200/8 FED-QQ-A-225/8 FED-QQ-A-200116 MIL-T-7081 FED-QQ-A-250/11 FED-QQ-A-250/11 FED-QQ-A-200/8F FED-QQ-A-200/9
7075-T6 7075-T6	Rods, rod material, rolled, drawn, cold finished Sheets, plates	AMS-4122 AMS-4045	FED-QQ-A-225/9 FED-QQ-A-250/12

We recommend that you take in due consideration the certificates on materials and coatings. The table shows an overview of SAE aerospace materials and federal specifications most commonly used. If you are looking for information on the thickness, elasticity and other properties of the material, please refer to the data sheets published by the Association of the Aluminum Processing Industry.

SURFACE ROUGHNESS

The RMS surface roughness increases when components are coated by Nituff® or hard anodized. The increase is dependent on the alloy, temperature, paint layer thickness and the original condition of the surface prior to coating. With 6061-T6 aluminum with a coating of 50 µm, the surface roughness increases slightly. In order to test different surface roughnesses, we recommend that you provide a sample or prototype prior to series production. This ensures we can achieve perfect results.

MANUFACTURING AND CONSTRUCTING SUITABLE FOR ANODIZING

GENERAL MATERIAL RECOMMENDATIONS FOR NITUFF® & HARD ANODIZING

RECOMMENDED RADII FOR NITUFF® AND HARD ANODIZING

Layer thickness	Radius
25 µm	> 0.1 mm
50 µm	> 0.2 mm
75 µm	> 0.3 mm

Pay attention to corners & edges!

Avoid sharp corners and edges since they increase the risk of surface damage. For example: Coating gaps or thin coating can emerge on the transition both on the inside and outside of the component. Rounded geometries, by contrast, have a positive effect on the coating result created by Nituff® and other types of hard anodizing.

A radius of 0.3 to 0.4 mm is recommended!

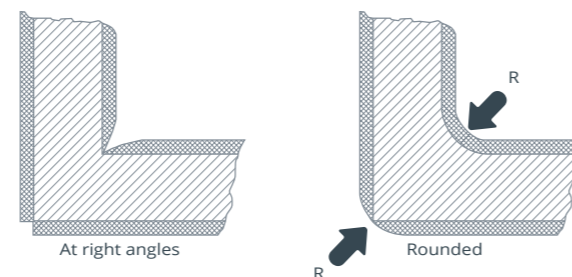

Pay attention to the change in the dimensions of the component!

Typically, coatings with Nituff® or hard anodizing have a thickness of 40 µm up to 60 µm. One-half of the original surface bonds with the surface of the component, the other half is added to the original surface. So please take into account the increase of the surface and mind precise adherence to tolerances.

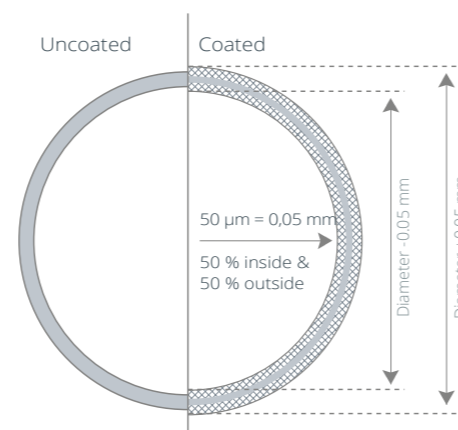

CALCULATION OF THE DIMENSIONS WHEN USING NITUFF® AND HARD ANODIZING

	External dimensions	Internal dimensions
Total dimensions & tolerance	2.000 ± 0.020 mm	2.000 ± 0.020 mm
Coating thickness & tolerance	0.050 ± 0.010 mm	0.050 ± 0.010 mm
Machined dimensions & tolerance	1.950 ± 0.010 mm	2,050 ± 0.010 mm

Uniformity of the coating in holes

Nituff® and hard anodized coatings follow the contours of a workpiece with a uniform and even build-up. The exterior walls of holes are coated in exactly the same way as the entire outside of the component when the depth of the hole does not exceed 3 times the diameter of the hole.

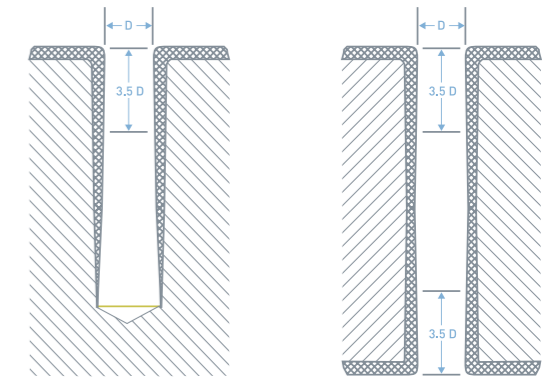

Passendes Bild einfügen



Platzhalter

CONSTRUCTIVE DESIGN AND PRODUCTION IN ACCORDANCE WITH DAST DIRECTIVE 022

The prerequisite for a good hot-dip galvanizing result is for the steel components to be constructed such that they allow for hot-dip galvanizing. In addition to the requirements entailed in this, which always had to be taken into account, there are a number of new regulations in DAST directive 022 that must be observed. The most important aspects are:

- The standards DIN EN ISO 1461, DIN EN ISO 14713, and, in addition, the DAST directive 022 must be observed in the planning process.
- When ordering steel, the information must be provided that the steel used meets the requirements of the DAST directive 022. According to these requirements, the steel products must be free from crack-like mistakes in the surfaces in accordance with DIN EN 10163 Part 2 for sheet metal and DIN EN 10163 Part 3 Class C, subgroup 1, for long products.
- In addition, the steel must have a minimum fracture toughness according to DIN EN 1993-1-10 Section 2, if it is welded.
- The application of professional free punches, flow-through openings and ventilation holes to hollow components and bulkheads or stiffening sheets
- Taking into account the maximum ratio of the material thicknesses at welded joints of up to $t_{max} / t_{min} < 5.0$
- The avoidance of overlapping surfaces, or consideration of proper relief bores and/or weld seam breaks
- Cold formed components require special attention. The directive limits the cold forming degree prior to hot-dip galvanizing to less than 2 %. With a greater degree of metal forming, the components must be heat-treated after the cold forming; or they must be heat-formed in the beginning; or have been qualified as free from defects and capable of being galvanized in advance in a so-called procedure test.
- Trusses welded together also require special attention. The findings in terms of their suitability for galvanizing require a procedure test. As an alternative, these trusses must be disassembled into their individual components, which are then galvanized separately.

FAQ DAST DIRECTIVE 022

1.

Who must comply with DAST directive 022? To which orders must it be applied?

The DAST directive aims at design engineers, steel construction companies, metalworkers, blacksmiths and galvanizers. It applies to load-bearing, hot-dip galvanized steel construction parts that are dimensioned and produced in accordance with DIN 18800 or DIN EN 1993 and DIN EN 1090-2, are made of construction steels according to DIN EN 10025 Parts 1-4, DIN EN 10210 or DIN EN 10219 and are classified as construction products under the Building Rules List. Currently, Building Rules List A Part 1 applies; the transition to Building Rules List B will be effected after the adoption of DAST directive 022 by a European regulation in EN 1090-2.

2.

Does the directive apply solely to heavy steel constructions or also to metalwork?

The application of DAST directive 022 is not based on the size of the components – it must be applied to all load-bearing constructions intended for hot-dip galvanizing that are used according to the Building Rules List in the area governed by building regulations. This ranges from large steel constructions, e.g. the construction of a hall, to typical work by metalworkers such as stairs, balconies, railings, shelter or car ports up to small metal items such as guardrails.

3.

Can very thick components be hot-dip galvanized under DAST directive 022?

In principle, no components are excluded from hot-dip galvanizing by the DAST directive. Hence very large material thicknesses can be hot-dip galvanized as well. For components whose reference value for the product thickness is greater than 30 mm, the exposure time must be limited to a maximum of 27 min. by the client in the order specification. The value, or possibly procedure tests, should be determined in consultation with the galvanizing company. In so doing, the relevant material thickness across the entire length of the component constitutes the reference value for the product thickness. For rolled and welded profiles, it is the greatest flange thickness of the respective profile, for example. Note: The rules concerning the thickness and dipping time have been inferred with regard to the prevention of the formation of cracks in the welded areas. Inasmuch as “thick” components have no welds, the rule does not have to be applied.

4.

Does the DAST directive only apply in Germany or abroad as well?

The DAST directive was introduced on a binding basis in Germany with the Building Rules List. It must currently be applied in Germany for load-bearing steel components within the meaning of Building Rules List A Part 1. The DAST directive does not apply abroad. However, its validity can be agreed upon individually as an integral part of a contract. In this case, it must be also applied abroad. Foreign companies (construction offices, manufacturing plants and hot-dip galvanizing firms) that process orders destined for Germany must comply with the DAST directive in the same way as German companies. Thus a foreign galvanizing operation is subject to third-party monitoring in accordance with the conformity certificate (ÜZ) procedure and must prove it with the conformity mark (Ü mark).

FAQ CONTINUED

DASt DIRECTIVE 022

5.

As of when is it compulsory to apply the DASt directive 022? Is there is an introductory or transitional period?

The compulsory application of the directive took effect with the publication of the revised Building Rules List 212009 on Dec. 22, 2009, by the German Institute for Building Technology (DIBt). This publication took place in December 2009. With this, DASt directive 022 must be applied on a binding basis. There is no transitional period.

6.

What are Building Rules List A and Building Rules List B?

The Building Rules Lists of the German Institute for Building Technology (DIBt) govern the mandatory technical rules to be applied under building law. In Building Rules List A Part 1 – in the future: Building Rules List B – the technical rules for construction products (i.e. standards and directives) themselves, the required conformity certificates as well as the required proof of usability in the case of deviations from the technical rules are defined. Regulated construction products are construction products for which technical rules exist. In this case, the technical rule “DASt directive 022” is introduced in Building Rules List A for the construction product “Load-bearing hot-dip galvanized steel components”.

7.

What are regulated construction products within the meaning of Building Rules List A Part 1?

Regulated construction products comply with the technical rules defined in Building Rules List A or B or do not significantly deviate from them. Building Rules List A and B only applies to construction products in the area of responsibility of the state building codes. It applies to all buildings and structures with the exception of:

- Buildings and structures of public transport including accessories, secondary structures and secondary operations to the extent they are in the regulatory area of the Federal Ministry of Transport, Building and Urban Development (BMVBS)
- Structures under supervision of the mining control authority
- Lines that are used for the public supply of water, gas, electricity, heat, public waste water disposal or telecommunications, including their masts, supports, as well as underground systems and equipment
- Piping for the long-range transport of substances and materials, including their underground systems and facilities
- Cranes on crane tracks (depending on the building code of the respective federal state). The Building Rules List or excerpt thereof can apply in these areas on the basis of a decree or, in individual cases, by contract.

8.

What do I as an architect or engineer need to observe in the context of DASt directive 022?

If you as an architect or engineer tender load-bearing steel components and leave the execution planning, detailed planning and/or production and steelwork planning to the planning engineers or steel/metal work-

ing company, you only have to update the tender specification in terms of hot-dip galvanizing. Architects and engineers who carry out the execution planning, detailed planning and/or production planning and steel construction planning for load-bearing steel components must take the requirements of DASt directive 022 into account as early as in the planning stage.

This includes, for example, the simplified verification procedure as well as the requirements for construction design and production in accordance with DASt directive 022.

9.

What do I as a steel or metalworker need to observe in the context of DASt directive 022?

Steel and metal construction companies as well as metalworking shops must comply with DASt directive 022 in the planning, construction and production of load-bearing steel components. The responsibilities specified in Table 1 of DASt directive 022 (simplified verification and order specification) and the delivery conditions for steel components to the galvanizing operation, in particular, must be observed under DASt directive 022.

10.

Who decides whether an order must be processed according to DASt directive 022?

The determination of whether a galvanizing order must be done in accordance with DASt directive 022 is based on the location of the building and the relevant building code. The planning company, steel construction company or metalworking company can be the client.

11.

How are cold formed components taken into account in DASt directive 022?

Cold formed components require special attention. The directive limits the cold forming degree prior to hot-dip galvanizing to less than 2 percent. With a greater degree of metal forming, the components must be heat-treated after the cold forming; they must be heat-formed in the beginning; or have been qualified as free from defects and capable of being galvanized in advance in a so-called procedure test.

12.

Who determines which test requirements may be necessary after the galvanizing?

With the determination of the trust zone on the part of the client, it is clearly defined which test requirements there are after the galvanizing.

- For components of trust zone 1, a 100 % visual inspection is carried out.
- For components of trust zone 2, a 100 % visual inspection; in addition, random checks by means of magnetic particle testing are performed.
- For components of trust zone 3, a 100 % visual inspection; in addition, a systematic check with the 12-magnetic powder method is conducted. Usually, the client's structural engineer is involved, who might demand more stringent testing in special cases.

FAQ CONTINUED

DASSt DIRECTIVE 022

13.

How does the galvanizing operation proceed in the case of missing order specification?

According to DASSt directive 022, the order specification from the client is mandatory for a galvanizing order. Without a complete order specification, processing the order at the galvanization operation is not permitted according to DASSt directive 022. On the part of the galvanizing company, a declaration of conformity with the DASSt directive by means of the Ü mark (conformity mark) may only be given if an order specification has been provided by the client and compliance with the DASSt directive in the planning and production has been confirmed.

14.

To what extent is the galvanizing company obligated to advise the client about DASSt directive 022?

According to DASSt directive 022, the galvanizer has a general obligation to advise the customer. Advising refers to aspects of construction and production suitable for hot-dip galvanizing.

15.

Who is responsible for performing the magnetic particle test?

The client usually orders the magnetic particle test by stating the trust zone in the order specification; in special cases, in an additional test specification. The responsibility for a proper performance of the magnetic particle test lies with the galvanizing company. It can either perform the test with its own trained test personnel or task an external institute with the test.

16.

How does the galvanizing company proceed if the specified exposure time in the molten zinc of ≤ 27 was exceeded?

For components whose reference value for the product thickness is greater than 30 millimeters, the exposure time must be limited to a maximum of 27 min. by the client in the order specification. In the event that this exposure time is not sufficient for the complete galvanizing of the components, the exposure time can be exceeded; in this case, an additional procedure test with 100 % inspection of all relevant places on the component is carried out. The test result must be documented and the client be informed about the excess exposure as well as the test results.

17.

Does The Coatinc Company meet the requirements of DIN EN 1090 in the area of hot-dip galvanizing?

Yes, the requirements are met since all galvanizing facilities have been certified according to DASSt directive 022.

FAQ

HOT-DIP GALVANIZING

1.

How durable is hot-dip galvanizing?

Hot-dip galvanizing is an extremely long-lasting corrosion protection. Under normal conditions, it protects the part for more than 40 years against corrosion; even with a higher level of exposure (e.g. in industrial air or at the sea coast), the duration of the protection is over 25 years.

2.

Is hot-dip galvanizing a reliable method?

The zinc coat offers reliable corrosion protection; it is created industrially and under defined conditions in accordance with DIN EN ISO 1461. Requirements for the properties and reliability of hot-dip galvanizing have thus been clearly laid down.

3.

Is hot-dip galvanizing a particularly heavy-duty corrosion protection?

Hot-dip galvanizing has unique properties. A metallic zinc coat that is inseparably bonded with the steel by an alloy offers unrivaled protection against damage during transport, installation and service. It is tough, shock-resistant and abrasion-resistant

4.

What are the costs of hot-dip galvanizing in comparison with other types of coating?

Hot-dip galvanizing is normally not more expensive than other conventional protection systems for steel. The industrial process is highly reliable and can be carried out very economically. It holds up to any price comparison.

5.

Does hot-dip galvanizing need to be maintained?

Hot-dip galvanizing is maintenance-free. This makes it one of the most reasonably priced long-term protection systems (because it provides protection for a longer time and does not cause follow-up costs). Keep in mind that especially maintenance and upkeep work give rise to additional costs and problems – in particular in hard-to-reach places. Maintenance-free corrosion protection saves you a great deal of money.

6.

Are there other advantages in the galvanizing of edges and cavities?

Conventional corrosion protection systems have problems mainly with edges and corners since the protective layer is too thin in these spots. No problem for hot-dip galvanizing: The zinc coat is of the same high quality in corners and on edges, in nooks and cavities.

FAQ CONTINUED

HOT-DIP GALVANIZING

7.

What is the cathodic protective effect?

In the unlikely event of damage caused by transport, installation or service, the cathodic protection takes over and builds up a barrier electrochemically. Hence corrosion doesn't stand a chance even with scratches and chips.

8.

Can the quality of zinc coatings be easily checked?

Zinc coatings can be easily checked even by lay persons. The eye is not deceived. Flaws can be detected immediately; they are not hidden. If the zinc coat looks even and uniform, it actually is.

9.

Does galvanizing save time?

As an industrial process, hot-dip galvanizing can be performed at optimal conditions in a short time and is completely independent of the weather. No time is wasted for corrosion protection at the construction site. Hot-dip galvanizing is immediately fully resistant after the process.

10.

Are there visual design options?

Metallic zinc coatings enhance the character and the properties of the steel. The metallic appearance and the surface structure of steel are unmistakably preserved. Metallic coats with zinc form a unit with the substrate that looks good. If color is desired - no problem! Hot-dip galvanizing and color coating = duplex system.

11.

How environmentally friendly is galvanizing actually?

Hot-dip galvanizing is environmentally friendly in two ways: On the one hand, the production conditions in a galvanizing operation in terms of recycling management are ideal: waste air, waste water, waste heat and waste products are reduced, cleaned, recycled and reused. On the other hand, hot-dip galvanized steel is easily recyclable and reusable. More than 80 % of the zincs available in Germany are recycled.

FAQ

DUPLEX

1.

What is the difference between a coat and a coating?

Layers of metal are called coats, layers of coating materials are called coatings (see DIN 50902).

2.

What is a coating material?

A liquid, pasty or powdery pigmented product that, applied to a substrate, results in an opaque coating with protective, decorative or specific properties (see DIN EN ISO 12944-1).

3.

What is a coating system?

The entirety of the layers of coating materials that are to be or have been applied to a substrate in order to provide corrosion protection (see DIN EN ISO 12944-1).

4.

What is a hydro-coating?

Coatings made of water-dilutable coating materials.

5.

What is a corrosion protection system?

The entirety of the layers of metals and/or coating materials that are to be or have been applied to a substrate in order to prevent corrosion (see DIN EN ISO 12944-1).

6.

What is a duplex system?

A corrosion protection system consisting of a zinc coating in combination with one or several subsequent coatings (see DIN EN ISO 12944-5).

7.

What is white rust?

White to dark gray corrosion products on galvanized surfaces (see DIN EN ISO 12944-4).

8.

What does surface preparation mean?

The totality of all milling processing for the preparation of a surface (example: pickling, blasting) for coating (see DIN EN ISO 12944-4).

FAQ CONTINUED

DUPLEX

9.

What is the so-called surface pretreatment?

The entirety of all processes for the preparation of a surface on which transformation coats are formed (example: phosphating, see ISO 8444).

10.

What is the sweep blasting (sweeping)?

Gentle blasting for the purpose of cleaning and roughening surfaces (see DIN EN ISO 12944-4).

11.

Can the duration of the protection be increased?

The protection duration of duplex systems is usually significantly longer than the sum of the respective individual protection duration of the zinc coat and the coating. It is called a synergy effect. Depending on the system, the extension factor is between about 1.2 and 2.5.

12.

Is a color design for the galvanizing possible?

In addition to the metallic zinc coat, it is possible with duplex systems to make use of the full range of color designs with the coatings.

13.

Can additional effects be achieved?

For some objects, a color coding for identification or to give a warning is required. With the help of suitable coating materials, objects can be matched to the environment or a camouflage effect be achieved.

SPACE

FOR SKETCHES AND NOTES



MAXIMUM CAPACITIES

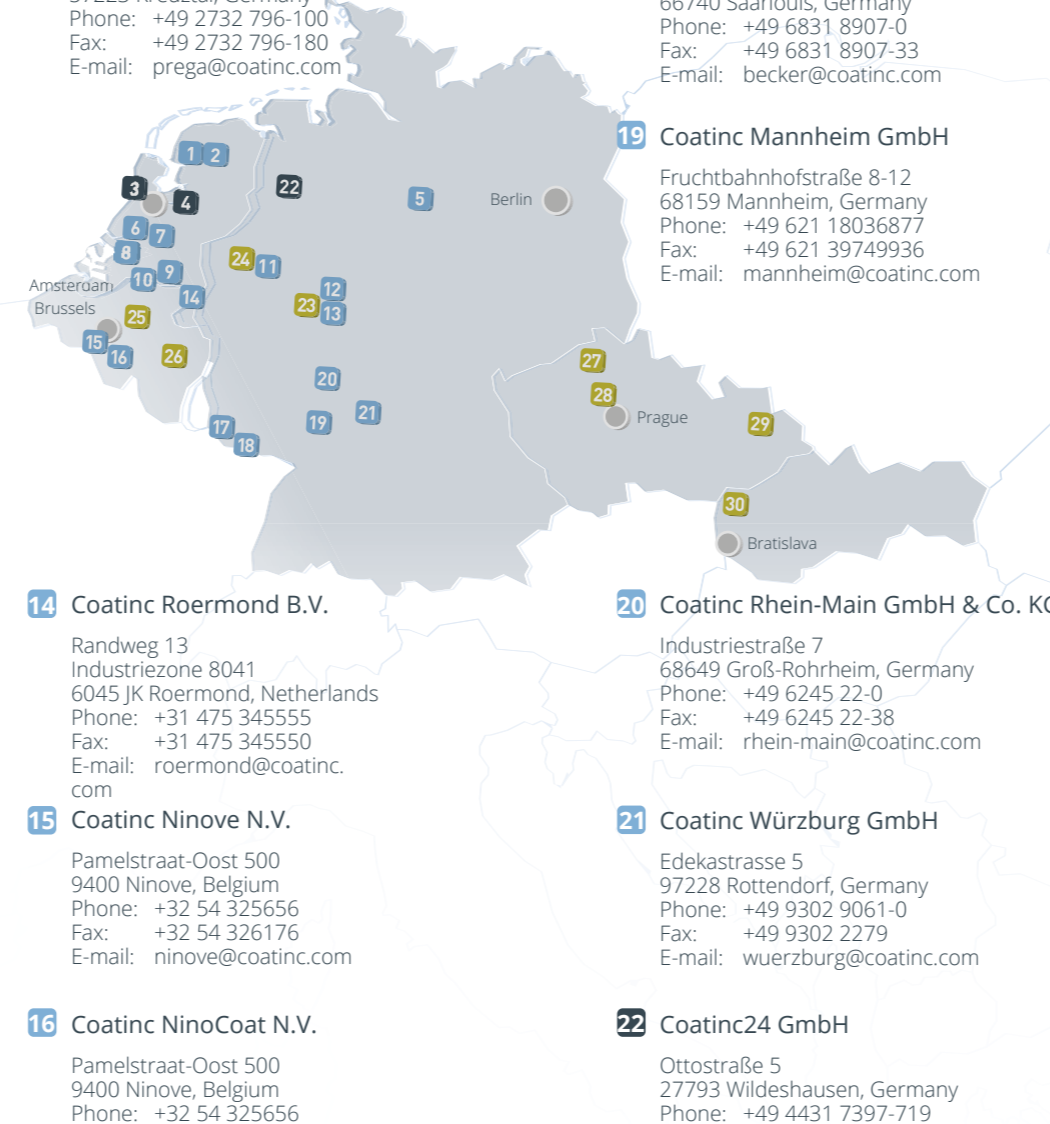

- 1** **Coatinc Groningen B.V.**
Rouaanstraat 49
9723 CC Groningen, Netherlands
Phone: +31 50 3176630
Fax: +31 50 3138326
E-mail: groningen@coatinc.com
- 2** **Coatinc Groningen Poedercoat B.V.**
Rouaanstraat 49
9723 CC Groningen, Netherlands
Phone: +31 50 3176630
Fax: +31 50 3138326
E-mail: groningen@coatinc.com
- 3** **Coatinc24 Amsterdam**
Noorder IJ- en Zeeweg 2
1505 HG Zaandam, Netherlands
Phone: +31 20 6368111
Fax: +31 20 6320541
E-mail: amsterdam@coatinc.com
- 4** **Coatinc Hop B.V.**
Gildeweg 22 (industrieterrein Harselaar)
3771 NB Barneveld, Netherlands
Phone: +31 342 419910
Fax: +31 342 492005
E-mail: hop@coatinc.com
- 5** **Coatinc Peine**
Industrial premises of Coatinc Bochum GmbH
Ackerköpfe 7
31249 Hohenhameln/Mehrum, Germany
Phone: +49 5128 9406-0
Fax: +49 5128 9406-70
E-mail: peine@coatinc.com
- 6** **Coatinc De Meern B.V.**
Strijkviertel 39b
3454 PJ De Meern, Netherlands
Phone: +31 30 6664395
Fax: +31 30 6665465
E-mail: demearn@coatinc.com
- 7** **Coatinc Anox B.V.**
Industrielaan 17
3925 BD Scherpenzeel, Netherlands
Phone: +31 33 2771669
Fax: +31 33 2772323
E-mail: anox@coatinc.com
- 8** **Coatinc Alblasserdam B.V.**
Edisonweg 5
2952 AD Alblasserdam, Netherlands
Phone: +31 78 6913733
Fax: +31 78 6915195
E-mail: alblasserdam@coatinc.com
- 9** **Coatinc Mook B.V.**
Bovensteweg 56
6585 KD Mook, Netherlands
Phone: +31 24 6962041
Fax: +31 24 6961209
E-mail: mook@coatinc.com
- 10** **Coatinc PreGa NL B.V.**
Bovensteweg 58
6585 KD Mook, Netherlands
Phone: +31 24 763006-0
Fax: +31 24 763006-9
E-mail: prega.nl@coatinc.com
- 11** **Coatinc Bochum GmbH**
Carolinenglückstrasse 6-10
44793 Bochum, Germany
Phone: +49 234 52905-0
Fax: +49 234 52905-30
E-mail: bochum@coatinc.com
- 12** **Coatinc Siegen GmbH**
Hüttenstraße 45
57223 Kreuztal, Germany
Phone: +49 2732 796-0
Fax: +49 2732 796-13258
E-mail: siegen@coatinc.com
- 13** **Coatinc PreGa GmbH**
Hüttenstraße 45
57223 Kreuztal, Germany
Phone: +49 2732 796-100
Fax: +49 2732 796-180
E-mail: prega@coatinc.com
- 14** **Coatinc Roermond B.V.**
Randweg 13
Industriezone 8041
6045 JK Roermond, Netherlands
Phone: +31 475 345555
Fax: +31 475 345550
E-mail: roermond@coatinc.com
- 15** **Coatinc Ninove N.V.**
Pamelstraat-Oost 500
9400 Ninove, Belgium
Phone: +32 54 325656
Fax: +32 54 326176
E-mail: ninove@coatinc.com
- 16** **Coatinc NinoCoat N.V.**
Pamelstraat-Oost 500
9400 Ninove, Belgium
Phone: +32 54 325656
Fax: +32 54 326176
E-mail: ninocoat@coatinc.com
- 17** **Coatinc Becker GmbH**
Wet Coating
Am alten Eisenwerk 2
66740 Saarlouis, Germany
Phone: +49 6831 8907-0
Fax: +49 6831 8907-33
E-mail: becker@coatinc.com
- 18** **Coatinc Becker GmbH**
Coatinc Becker Lisdorfer Berg
Zum Geisberg 1
66740 Saarlouis, Germany
Phone: +49 6831 8907-0
Fax: +49 6831 8907-33
E-mail: becker@coatinc.com
- 19** **Coatinc Mannheim GmbH**
Fruchtbahnstraße 8-12
68159 Mannheim, Germany
Phone: +49 621 18036877
Fax: +49 621 39749936
E-mail: mannheim@coatinc.com
- 20** **Coatinc Rhein-Main GmbH & Co. KG**
Industriestraße 7
68649 Groß-Rohrheim, Germany
Phone: +49 6245 22-0
Fax: +49 6245 22-38
E-mail: rhein-main@coatinc.com
- 21** **Coatinc Würzburg GmbH**
Edekastrasse 5
97228 Rottendorf, Germany
Phone: +49 9302 9061-0
Fax: +49 9302 2279
E-mail: wuerzburg@coatinc.com
- 22** **Coatinc24 GmbH**
Ottostraße 5
27793 Wildeshausen, Germany
Phone: +49 4431 7397-719
Fax: +49 4431 7397-535
E-mail: info@coatinc24.com
- 23** **ESP Pulverbeschichtung GmbH**
Hüttenstraße 47
57223 Kreuztal, Germany
Phone: +49 2732 796-0
Fax: +49 2732 796-240
E-mail: siegen@coatinc.com
- 24** **ESP Pulverbeschichtung GmbH**
Carolinenglückstr. 6
44793 Bochum, Germany
Phone: +49 234 52905-0
Fax: +49 234 52905-30
E-mail: bochum@coatinc.com
- 25** **Rezinal N.V.**
Industrial Zone Zolder-Lummen Zuid
Dell straat 17
3550 Heusden-Zolder, Belgium
Phone: +32 13 539630
Fax: +32 13 521674
E-mail: info@rezinal.be
- 26** **Verzinkerij Lenssen N.V.**
H. Fordlaan, 29
3600 Genk, Belgium
Phone: +32 89 613420
Fax: +32 89 613422
E-mail: info@lenssen.be
- 27** **ZinkPower Promptus s.r.o.**
Krokova 6
405 02 Decin, Czech Republic
Phone: +420 412 557011
Fax: +420 412 511974
E-mail: promptus@zinkpower.com
- 28** **ZinkPower Roudnice s.r.o.**
Hájkova 2490
413 01 Roudnice nad Labem, Czech Republic
Phone: +420 416 841524
Fax: +420 416 841525
E-mail: roudnice@zinkpower.com
- 29** **ZinkPower Ostrava a.s.**
Vratimovska 516
719 00 Ostrava-Kuncice, Czech Republic
Phone: +420 595 245960
Fax: +420 595 245969
E-mail: ostrava@zinkpower.com
- 30** **ZinkPower Malacky s.r.o.**
Továrenská 17
90101 Malacky, Slovakia
Phone: +421 34 7731441
Fax: +421 34 7731442
E-mail: malacky@zinkpower.com
- 31** **Marmara-Siegenger Galvaniz A.Ş.**
Çerkeşli Mah.
İMES 5. Cadde No: 11
41455 Dilovası/Kocaeli, Turkey
Phone: +90 262 72293-84
Fax: +90 262 72293-83
E-mail: info@galvaniz.com
- 32** **Marmara-Siegenger Galvaniz A.Ş.**
Sanayi Mah.
Hayrettin Uzun Cad.
Köşk Sok. No: 10
İzmit/Kocaeli, Turkey
Phone: +90 262 33505-95
Fax: +90 262 33505-94
E-mail: info@galvaniz.com
- 33** **Marmara-Siegenger Galvaniz A.Ş.**
Çorlu Velimeşe OSB.
341. Ada 11. Parsel
Ergene/Tekirdağ, Turkey
Phone: +90 262 33505-95
Fax: +90 262 33505-94
E-mail: info@galvaniz.com
- 34** **California Galvanizing & Steel Structures, Inc.**
809 Bowsprit Rd Suite 207
Chula Vista, CA, 91914 / U.S.
Phone: +1 619 6387261
E-mail: info@californiagalvanizing.us.com
- 35** **Galvanizadora California, S.A.P.I. de C.V.**
Calle Valle Redondo s/n
Colonia Valle Redondo
Tijuana, Baja California, 22185 Mexico
Phone: +52 664 3816350
E-mail: info@galvanizadoracalifornia.com

■ Locations
 ■ Participations
 ■ Sales companies



Hot-dip galvanizing
Maximum component length, single dipping: 19.2 m
Maximum component length, double dipping: 30 m
Maximum component height/width: 5 m
Maximum component weight: 18 t



High-temperature galvanizing
Maximum component weight: 800 kg
Maximum component length: 4 m



Centrifugal galvanizing
Maximum component weight: 3 kg/unit
Maximum component dimension: 0.3 x 0.05 x 0.05 m (per unit)



Passivation
Maximum component length: 20 m
Maximum component height: 4 m



Anodization
Maximum component dimension: 7.2 x 1.25 x 0.55 m



Powder coating
Maximum component weight: 3.5 t
Maximum component dimension: 14.5 x 3.0 x 1.1 m



Wet coating
Maximum component weight: 6.4 t
Maximum component dimension: 30 x 2.5 x 0.8 m

Combinations of maximum dimensions on request.



The Coatinc Company®

We galvanize dreams – since 1885
www.coatinc.com

LOCATIONS

THE COATINC NETWORK

GERMANY

Bochum
Groß-Rohrheim
Mannheim
Peine
Saarlouis - Plant 1
Saarlouis - Plant 2
Siegen
Siegen - PreGa
Wildeshausen
Würzburg

NETHERLANDS

Alblasserdam
Amsterdam
Barneveld

De Meern
Groningen - Plant 1
Groningen - Plant 2
Mook
Mook - PreGa
Roermond
Scherpenzeel

BELGIUM

Ninove - NinoCoat
Ninove

CZECH REPUBLIC

Děčín
Ostrava-Kuncice
Roudnice

SLOVAKIA

Malacky

TURKEY

Çorlu
Gebze
Izmit

UNITED STATES

Chula Vista, CA

MEXICO

Tijuana

THE COATINC COMPANY HOLDING GMBH

HEADQUARTER

Carolinenglückstraße 6-10
44793 Bochum, Germany
Telephone: +49 234 52905-25
Fax: +49 234 52905-15
Email: holding-de@coatinc.com

COATINC IN THE WORLD WIDE WEB

Visit our website
www.coatinc.com
or connect with us
through social media.



OUR CERTIFICATIONS AT A GLANCE



To learn more about our units or obtain specific technical information, please contact us or download information at: www.coatinc.com/media/downloads